

CHAPTER I

1.1 PRESENTATION

Aimpoint Micro T-1 Reflex Sight is a small, light and rugged red dot sight developed mainly for military and law enforcement applications.

Aimpoint red dot sights are designed for the "two eyes open" method of sighting, which greatly enhances situational awareness and target acquisition speed. Thanks to the parallax-free design, the dot follows the movement of the user's eye while remaining fixed on the target, eliminating any need for centering. Further, the Micro T-1 allows for unlimited eye-relief and is compatible with 1st, 2nd and 3rd generation night vision devices.

The Aimpoint Micro T-1 sight uses the new Advanced Circuit Efficiency Technology, called ACET, which combines Aimpoint's superior accuracy and ease of use with significantly lower power usage.

With the Micro T-1 sight, Aimpoint has introduced an aiming system that gives the performance of our full-sized sights in the smallest package possible.

1.2 SPECIFICATIONS

Optical System

Operating Principle	Passive Red Dot Collimator Reflex Sight
Optical Magnification	1 x, unlimited eye relief
Clear Aperture	20 mm
Aiming Dot Size	4 MOA* (1.2 mRad)
Optical Coating	Anti reflex and Band Pass coatings, NVD** compatible

Dot Brightness

12 settings – 4 NVD and 8 Daylight of which 1 Extra Bright, Dot brightness manually adjusted
Red (650 nm wavelength)
No forward optical signature from the dot beyond 10 meters

Dot Color

Optical Signature

Power Source

Battery Type	One 3 V lithium battery, type CR2032, commercially available
Battery Life, typical	Over 5 years of continuous (day and night) use at pos 8 of 12 and over 10 months at pos 10 of 12. Typically 500 000 hours at NVD setting. Storage battery 10 years.

Values valid at room temperature and for a quality battery.

Physical Specifications

Dimensions (L x W x H)	62 mm x 41 mm x 36 mm (2.4" x 1.6" x 1.4"), Sight only 62 mm x 41 mm x 40 mm (2.4" x 1.6" x 1.6"), Sight with Mount
Height of optical axis	18 mm (0.7") over top surface of Picatinny Rail
Mass	84 grams (3.0 oz) Sight only, 105 grams (3.7 oz) Sight with Mount
Lens Covers	Lens Covers will add 7 mm (0.3") to the length and 10 grams (0.4 oz) to the weight
Adjustment:	Range ± 1 m at 100 meters (± 1 yds at 100 yds) in windage and elevation, 1 click = 10 mm at 80 meters = 13 mm at 100 meters = 1/2" at 100 yds
Material – Housing:	Extruded, high strength aluminum, hard anodized, black to dark grey, non-glare finish
Material - Lens Covers	Rubber, black, non-glare finish
Radioactive Materials	None (Tritium 0%, Thorium 0%, Thorium Fluoride 0%)
Hazardous Materials	None (Mercury 0%, including battery)

Environmental Specifications

Temperature Range,	
Operating and Storage	-45° C to +71° C (-50° F to +160° F)

Thermal Shock	-45° C to +71° C in 60 seconds and vice versa with temperature stabilization in between
Humidity	95% at 20° C (68° F) to 50° C (122° F), cycling
Immersion Shock	25 m (80 ft.)
Vibration	3 x 500 G 0.7-1.1 ms XYZ: 10-30 Hz: 3 mm, 30-150 Hz: 5.75 G for 30 minutes
Chemical Resistance	Not affected by weapons cleaners, lubricants, oil or insect repellants

Mechanical Interface

Keyed surface	Patent pending mount keyed to the sight body to absorb recoil
Keyed mount	Mount for MIL-STD 1913 Rail System "Picatinny Rail" included

Maintainability

Mean Time To Repair	Less than 0.5 hours at field level (MTTR)
---------------------	---

*MOA: Minute Of Angle
1MOA~ 30 mm at 100 meters or ~1" at 100 yards
**NVD: Night Vision Device

1.3 LOCATION AND DESCRIPTION OF MAJOR COMPONENTS

See figure

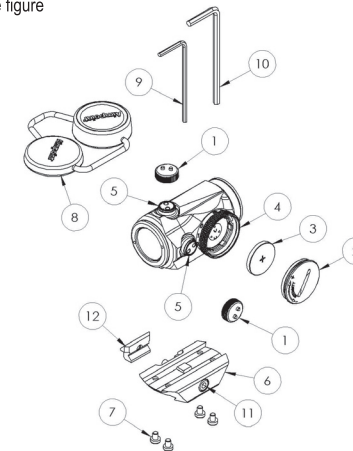

1. Adjustment Cap (2 pcs)
2. Battery Cap
3. Battery (type CR2032)
4. Rotary Switch
5. Adjustment Screw
6. Base
7. Screws (4 pcs) for Base
8. Lens Cover, rubber
9. Allen Wrench (size 2 mm)
10. Allen Wrench (size 3 mm)
11. Shaft (for Base)
12. Locking Bar

CHAPTER II

OPERATION UNDER NORMAL CONDITIONS

2.1. ASSEMBLY AND PREPARATION FOR USE

WARNING: Insure the weapon is unloaded and the safety selector is in the "safe" position before attempting to install, remove or perform maintenance on the sight.

2.1.1 Installing Battery

- Remove Battery Cap (2) by turning it counter clockwise.
- Insert a battery (type CR2032) with positive (+) end toward Cap. **Caution** while replacing battery (not necessary when the sight is new) Before installing Battery Cap (2), inspect that the O-ring is present and not damaged. Failure to do so could result in water leakage into the battery compartment.
- Install Battery Cap (2) by turning clockwise until snug. Hand tighten only - with a coin or similar. Using tools could damage equipment.
- Verify that red dot is present by turning the Rotary Switch (4) clockwise.

2.1.2 Installing Sight on the weapon

The Micro Sight is designed for installation on most types of weapons, which have a MIL-Std 1913 Picatinny Rail. If your weapon does not have or support an appropriate base(s), please consult your dealer, gunsmith or other qualified source.

2.1.2.1 Installing Sight on a Picatinny Rail

- Loosen the Shaft (11) by means of the Allen Wrench (10), so that the Locking Bar (12) can clamp around the Picatinny Rail.
- Install the Sight to the weapon Rail by tightening the Shaft (11). First, ensure that the Sight is correctly positioned and that the Shaft (11) (=recoil stop) fits into a groove on the Picatinny Rail. To make sure that the Shaft is firmly tightened, screw the Shaft (11) clockwise until a light resistance can be encountered. After that, screw another 1/4 to 1/2 turn. **WARNING!** Do not overtighten.
- When using Lens Covers (8), ensure that they are correctly positioned and can easily be opened.
- Finally, make sure that the Shaft (11) with Locking Bar (12) is firmly tightened around the weapon Rail.
- Complete zeroing according to 2.2.1 below.

2.1.3 Lens Covers

In order to preclude the loss of the lens covers when removed from the optical path of the Sight, the lens covers should be removed downwards. The rubber string will then grab around the Sight and Base.

2.2. OPERATING PROCEDURES

2.2.1 Zeroing

The Micro Sight is delivered with the red dot in a centered position. Normally this means that only small adjustments are necessary, providing that the weapon rail (Picatinny Rail) is properly aligned.

CAUTION: Do not continue to adjust windage and elevation mechanisms if you encounter resistance. The Elevation Adjustment Screw (5) is located on top of the sight, while the Windage Adjustment Screw (5) is located on the right side.

- Open (remove) Lens Covers (8).
- Turn the Switch Knob (4) clockwise until the red dot has a sufficient intensity to contrast against the target.
- Remove the Adjustment Cap (1) for windage and elevation adjustment, one at a time. The two knobs incorporated on top of the Adjustment Cap (1) shall be used for adjusting the Screw (5). Reverse the Adjustment Cap (1) and the knobs will fit into the two recesses on the Adjustment Screw (5).

NOTE: Each click of the Adjustment Screw (5) corresponds to a 13 mm movement of the point of impact at 100 meters, (3 mm at 25 meters and 26 mm at 200 meters or 1/2" at 100 yds).

- Insert the two knobs on top of the Adjustment Cap (1) in the two holes on the Adjustment Screw (5) and turn as follows:
 - To move the point of impact to the right, turn windage adjustment screw counter clockwise
 - To move the point of impact to the left, turn windage adjustment screw clockwise
 - To move the point of impact up, turn elevation adjustment screw counter clockwise.
 - To move the point of impact down, turn elevation adjustment screw clockwise.
- Confirm zeroing by firing at least three shots at a zeroing target. Check points of impact on zeroing target to confirm accuracy and repeat above procedure if required.
- After initial firing, ensure that the sight is secure.
- Turn Rotary Switch (4) to OFF position (counter clockwise).
- Close front and rear Lens Covers.

CHAPTER III

OPERATION UNDER EXTREME CONDITIONS

- Extreme heat (moist or dry).** No special procedures required.
- Extreme cold.** Extreme cold might shorten battery life. It could also make the Rotary Switch (4) a little harder to turn than at normal temperatures.
- Salt air.** No special procedures required.
- Sea spray, water, mud and snow.** Ensure that Battery Cap (2) and the two Adjustment Caps (1) are tightened before exposing the Sight to sea spray, mud, snow or before immersing the sight in water. Hand tighten only. Keep Lens Covers (8) closed when sight is not being used. Clean lenses with lens paper/cloth and wipe the sight dry as soon as possible after exposure to water, sea spray, mud or snow.
- Dust storms and sand storms.** Keep Lens Covers (8) closed when sight is not being used.
- High altitudes.** No special procedures required.

CAUTION: The lenses shall never be cleaned with fingers but with lens paper/cloth. If no lens paper/cloth available :

- To clear away debris (sand, grass etc): blow away the dirt.
- To clean lenses: mist up the lenses and clean them with a soft piece of cloth.

CHAPTER IV

TROUBLE SHOOTING PROCEDURES

4.1 RED DOT DOES NOT APPEAR

- | | |
|-------------------------------------|---|
| Discharged battery: | Replace battery. |
| Battery installed incorrectly: | Remove and reinstall battery with (+) toward Cap. |
| Battery is not making good contact: | Clean contact surfaces and reinstall battery. |
| Defective Rotary Switch: | Notify dealer/armourer. |

4.2 IMPOSSIBLE TO ZERO

- | | |
|-----------------------------------|--|
| Adjustment screw is at its limit: | Check alignment of mount to barrel. |
| Impact point is moving: | Check mount and weapon rail (or carry handle) stability. |

CHAPTER V

MAINTENANCE

- This reflex sight does not require any particular maintenance while used under normal conditions.
- Under severe weather conditions please refer to chapter III.
- Keep lens covers closed whenever the sight is not in use.
- Warehouse storage: Remove battery and allow lens surfaces to dry completely (if wet) before closing the lens covers.
- To clean lenses refer to CAUTION in chapter III.

Aimpoint®

Operator and
Maintenance Manual for
AIMPOINT MICRO T-1



Aimpoint AB
Jägershillgatan 15
SE- 213 75 Malmö, Sweden
Phone +46 (0)40 671 50 20
Fax +46 (0)40 21 92 38
e-mail: info@aimpoint.se
www.aimpoint.com

Aimpoint Inc.
14103 Mariah Court
Chantilly, VA 20151-2113, USA
Phone +1 703-263-9795
Fax +1 703-263-9463
e-mail: info@aimpoint.com
www.aimpoint.com

THE FUTURE IN SIGHT.

© 2007 - Contents property of Aimpoint - All rights reserved. [12034]